

# TAKEUCHI

HYBRID

TB 216



## HYBRID EXCAVATOR

The excavator with a double engine for in and outdoor performance

# VARIOUS ATTACHMENTS

GRAPPLE

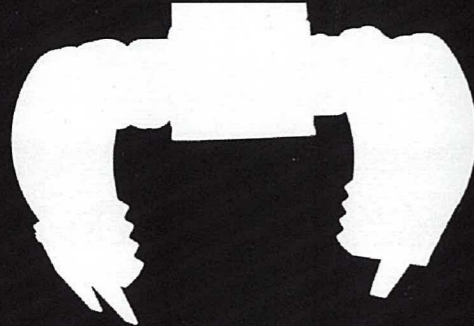

BUCKET



HYDRAULIC BREAKER



DEMOLITION PLIERS

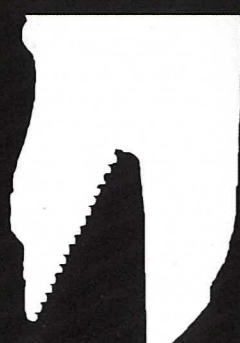

# TB 216

HYBRID

## The result of a decade of experience

For many years, Takeuchi has offered hybrid excavators. In addition to the standard existing diesel engine, these compact excavators, with a total weight of 0.8 t to 3.5 t, have been equipped with an electric motor. With its electric motor, the hybrid excavator can be used in enclosed spaces.

The latest development in the hybrid excavator field is the TB216 Hybrid. For the first time, with this model, a hybrid excavator is available in which the operation with the electric motor and diesel engine is identical. Even the speed of the motor is adjustable in electric mode on the throttle. Since the electric motor is completely maintenance-free, the operating costs of the hybrid TB216 is reduced to a minimum.

The result of over ten years of experience building hybrid excavators is a machine that is distinguished by particular efficiency and contributes to your success!

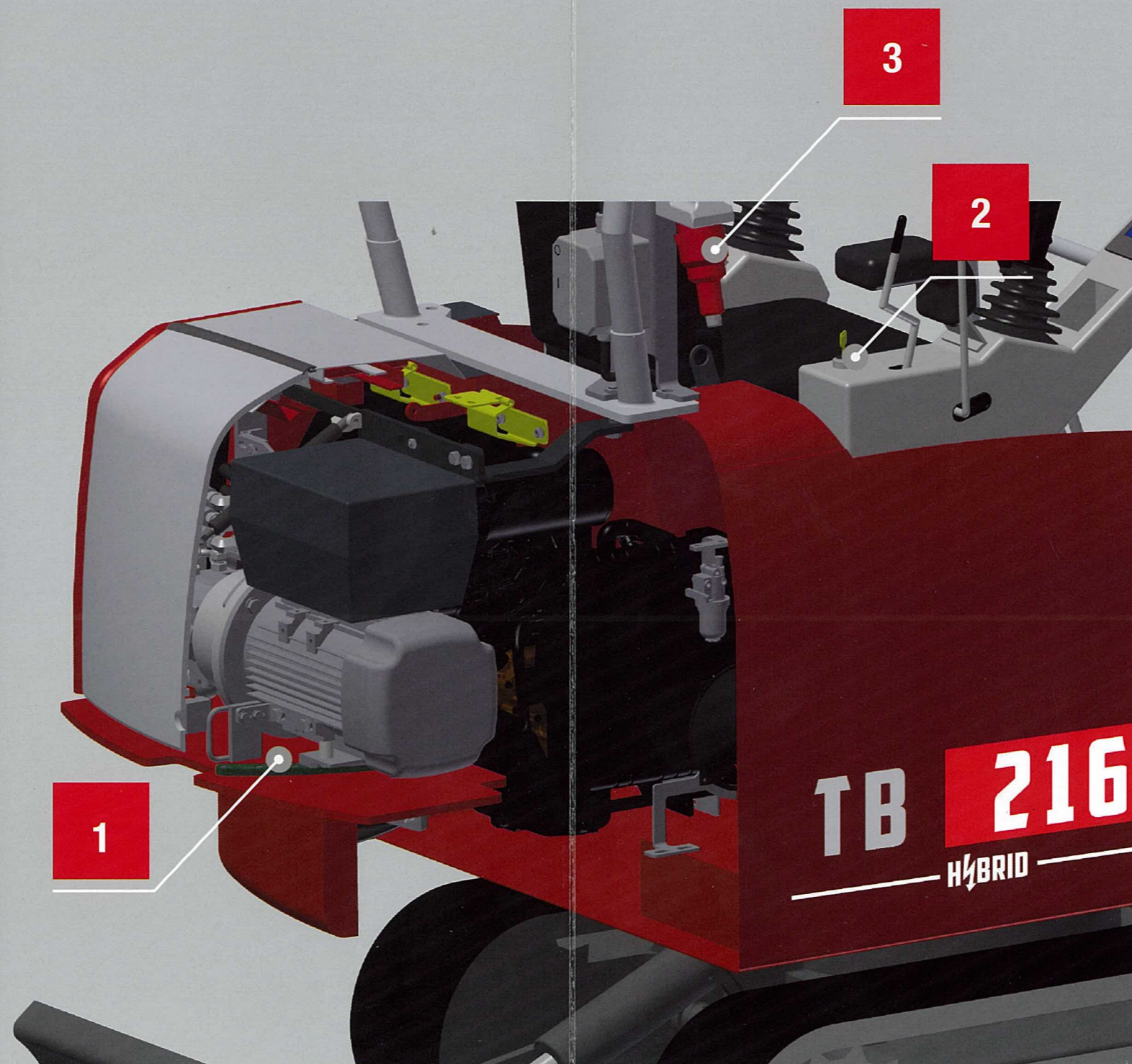

## 1 EASY TO MAINTAIN



- 1 No additional maintenance on the electric motor
- 1 Tool-free access to the diesel engine's service points

## 2 INTUITIVE OPERATION



- 1 Switch on and off with the ignition key
- 1 Power adjustment via the throttle
- 1 Automatic switch to the electric mode when the cable is connected

## 3 MAXIMUM EFFICIENCY



- 1 Low operating costs in the electric mode
- 1 Multiple application possibilities = high utilization rate
- 1 20% increase in performance compared to the previous model

# TECHNICAL DATA

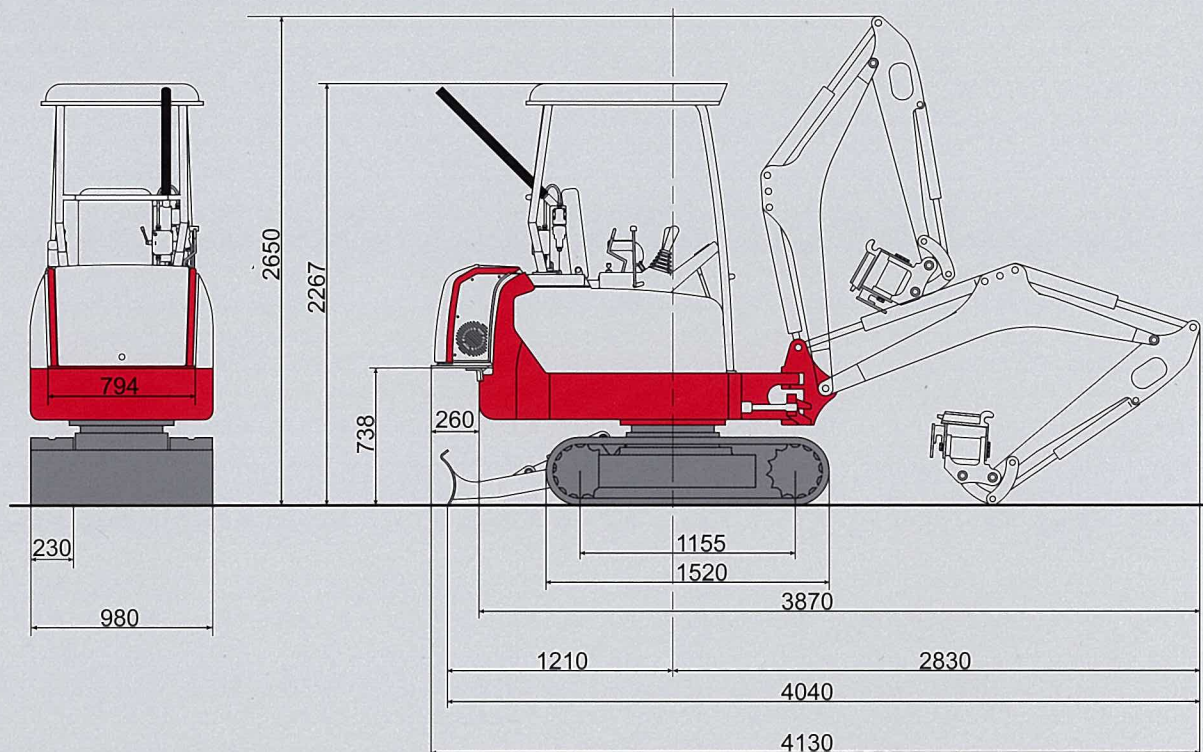

▮ Total weight:	1905 kg
▮ Output diesel engine:	11.1 kW/2400 rpm
▮ Output electric motor:	10.6 kW/2400 rpm
▮ Electrical connection:	400 V/50 Hz Safeguard 32A

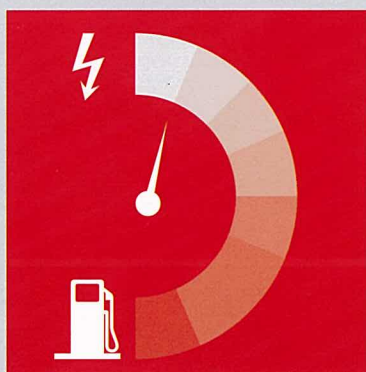

## ELECTRIC MOTOR

The high voltage connection allows for 100% emission-free use with full functionality and increased performance.

## DIESEL ENGINE

The original diesel engine remains intact. Thus, the machine can also be used as usual and problem-free transport to the site is made possible.



**DMS**  
DMS Technologie GmbH

In cooperation with  
DMS Technologie GmbH

Steinbacher Str. 62  
64658 Fürth

*ABS-MASKIN AS*  
Strandvn, 20 A - Postboks 94  
3051 MJØNDALEN  
Tlf. 32 23 18 10, Fax 32 23 18 11